

The “DECON”
RTP canister VHP decontamination system

Manufactured by:
Dynamic Design Pharma
Laguna Niguel, California
www.dynamicdesignpharma.com

Patent Pending

System Description

The DECON is a stand alone system that is used to VHP decontaminate an RTP canister using a standard VHP gas generator and interconnecting hardware.

Multiple DECON systems can be connected off a single VHP generator for those applications requiring simultaneous canisters decontamination.

The DECON consists of a small, leak tight chamber onto which the canister to be decontaminated is connected.

VHP gas is introduced into the system via a gas injection system and a mixing fan assure of proper gas distribution within the chamber and the canister.

The rear bulkhead of the enclosure features a manual mechanism that the operator operates to manipulate the canister door without entering the chamber.

Control hardware permits a pressure maintenance leak test of the system prior to VHP gas injection.

Features

- Stand alone, modular design eases placement and movement within the facility
- Stainless steel frame support the sealed chamber. Casters permit easy movement of the system while leveling feet permit secure placement of the system during operation.
- The system is designed in such a way that it can be interfaced with any RTP canister model and size
- The canister rests onto an adjustable supporting mechanism during the docking process.
- To assure of total coverage of all critical surfaces of the canister, a manual mechanism allows the operator to separate and move the canister door a certain distance from the beta flange. No gloves required.
- Control hardware permits running a pressure maintenance leak test of the system prior to VHP gas injection.
- VHP gas injection system permits injecting the gas into the chamber. Proper distribution is assured by a mixing fan.

Specification

- Nominal size: 600 mm wide x 1100 mm long x 1600 mm high
- RTP Canister type: Standard design for 270mm and 350mm beta flange. Can be adapted to interface to beta flanges of any type and dimension.
- VHP connections: 2-1/2 triclover connections for gas inlet and outlet
- Leak tightness: Capable of withstanding a 50pascal internal pressure without detectable leaks, using ammonia detection.
- Materials of construction: Stainless steel, silicone, polycarbonate. All VHP gas compatible.
- Movability/Safety: 3 swivel casters and 2 leveling feet

Advantages

- The DECON permits the rapid decontamination of the RTP canister, especially important in those applications where cross contamination is an issue and unidirectional material flow, meaning single canister use, are part of the process.
- The DECON increases the availability of the autoclave, often a manufacturing flow bottleneck, to sterilize parts, not canisters, and eliminates the long wait for proper cool down of the canister prior to use.
- The DECON eliminates using a transfer isolator to decontaminate canisters. With the system, the transfer isolator can be left “up”, yielding improved operational efficiency.
- The DECON reduces the reaction time of the operation in the event of an emergency where quick access to the isolator system is necessary.

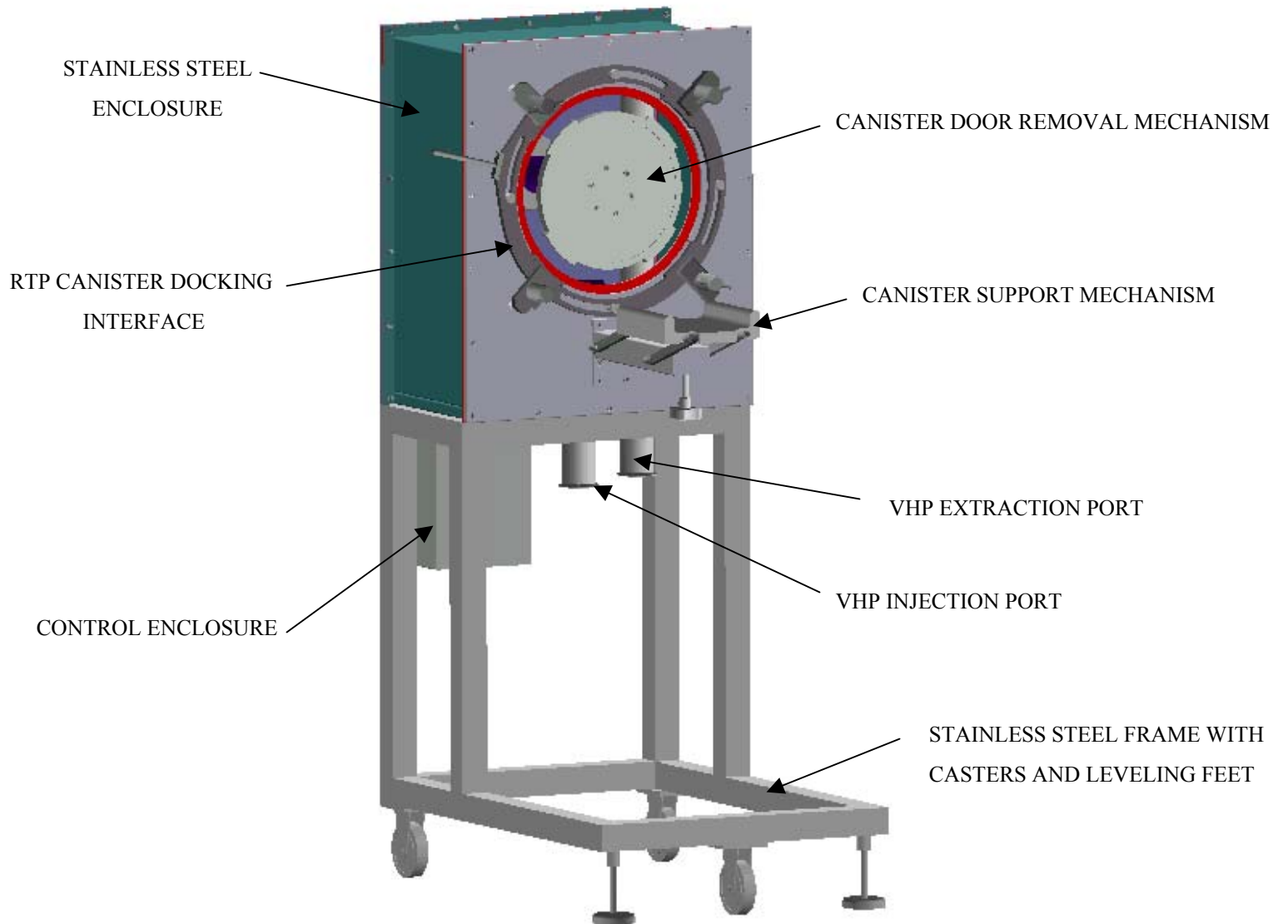

Front view of system

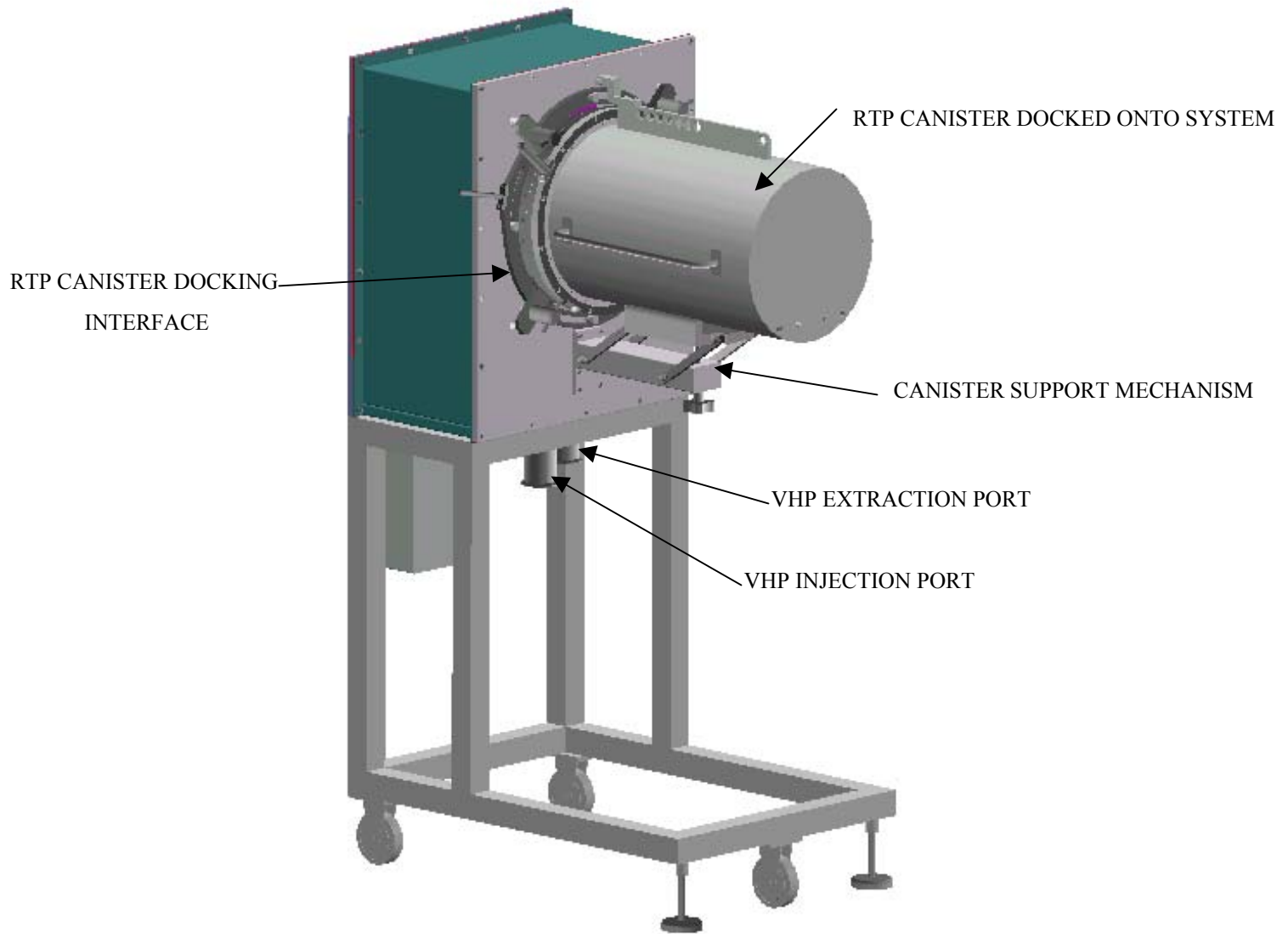

Front view with RTP canister docked

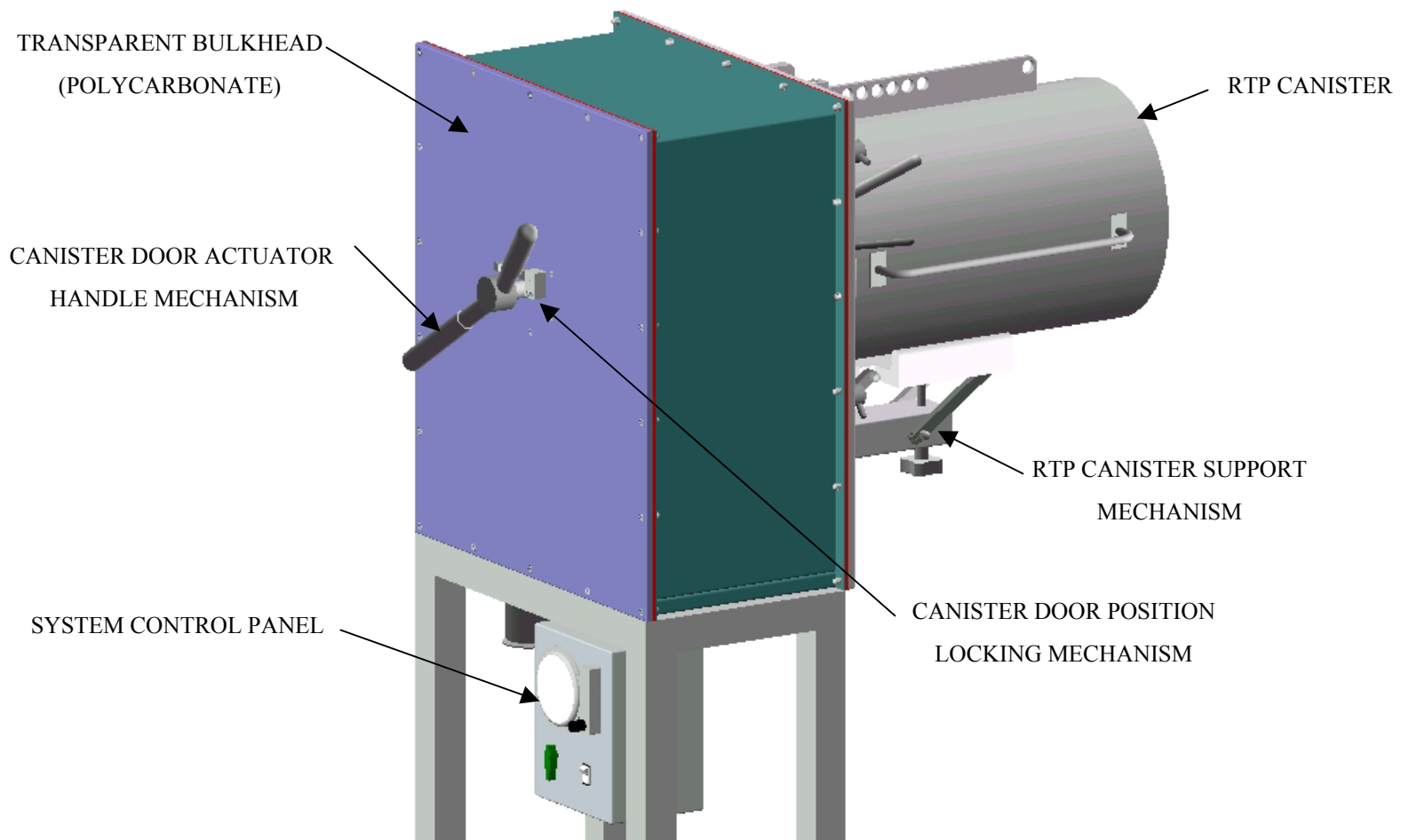

Rear view of system - with RTP canister docked

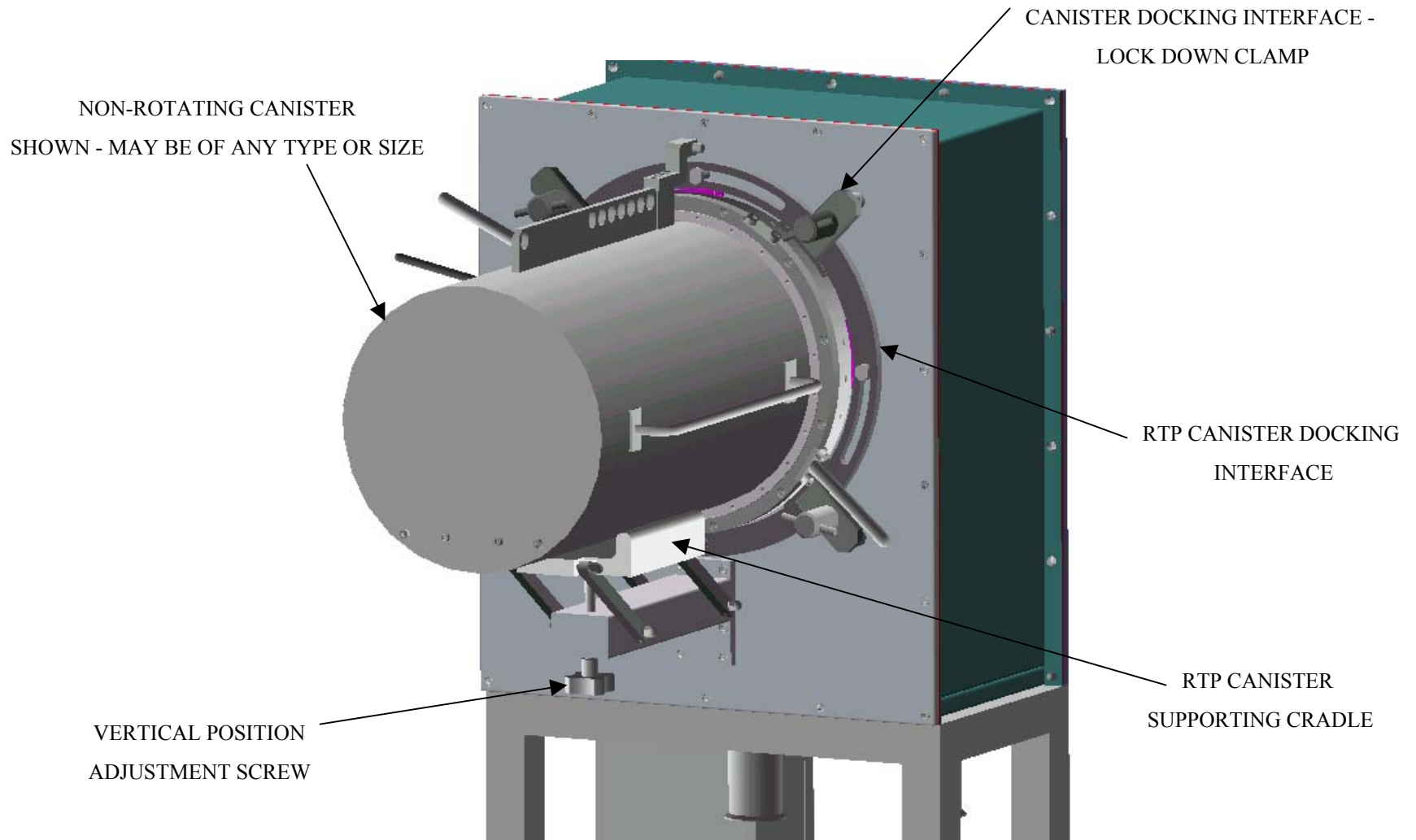

Front view close up - with RTP canister docked

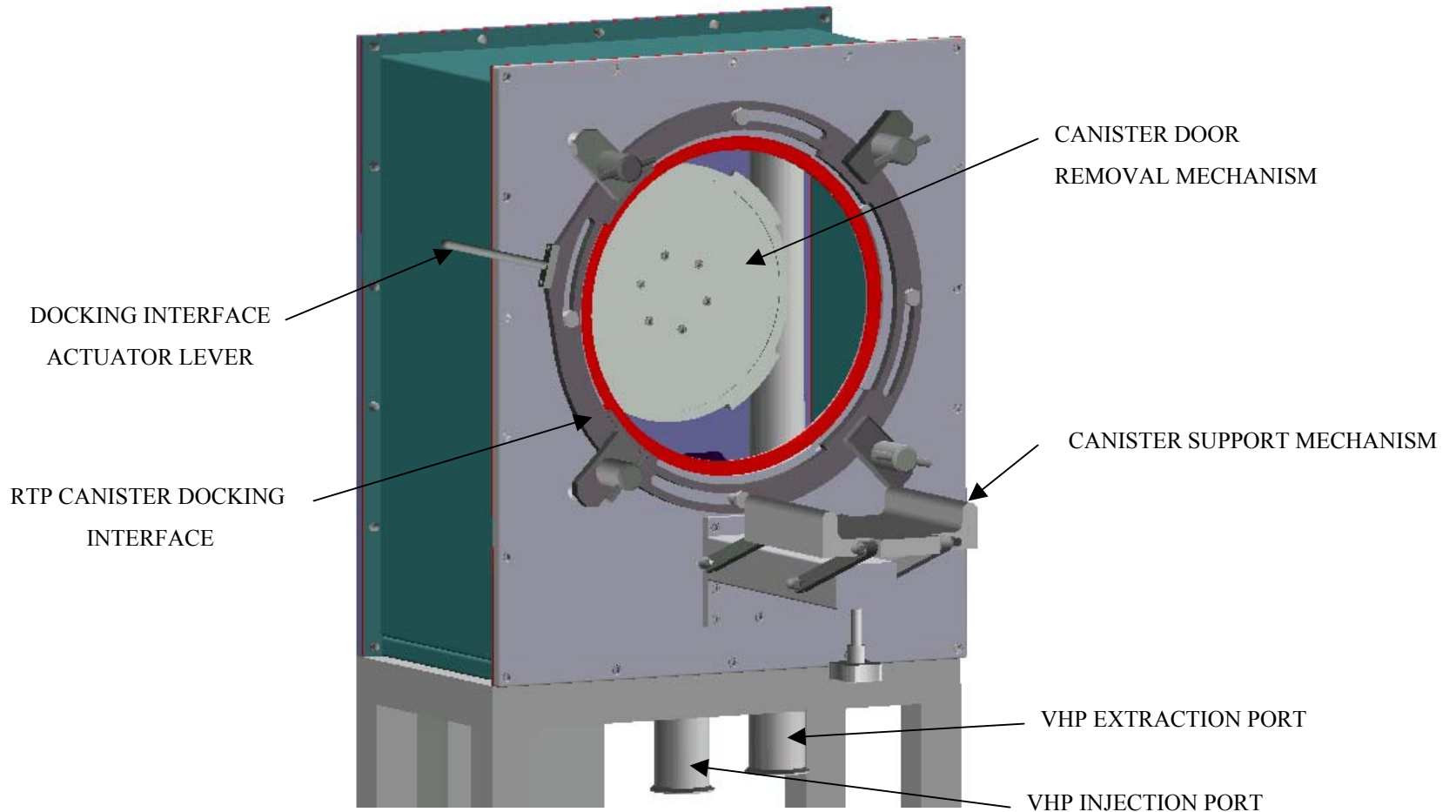

Front view close up - without RTP canister docked

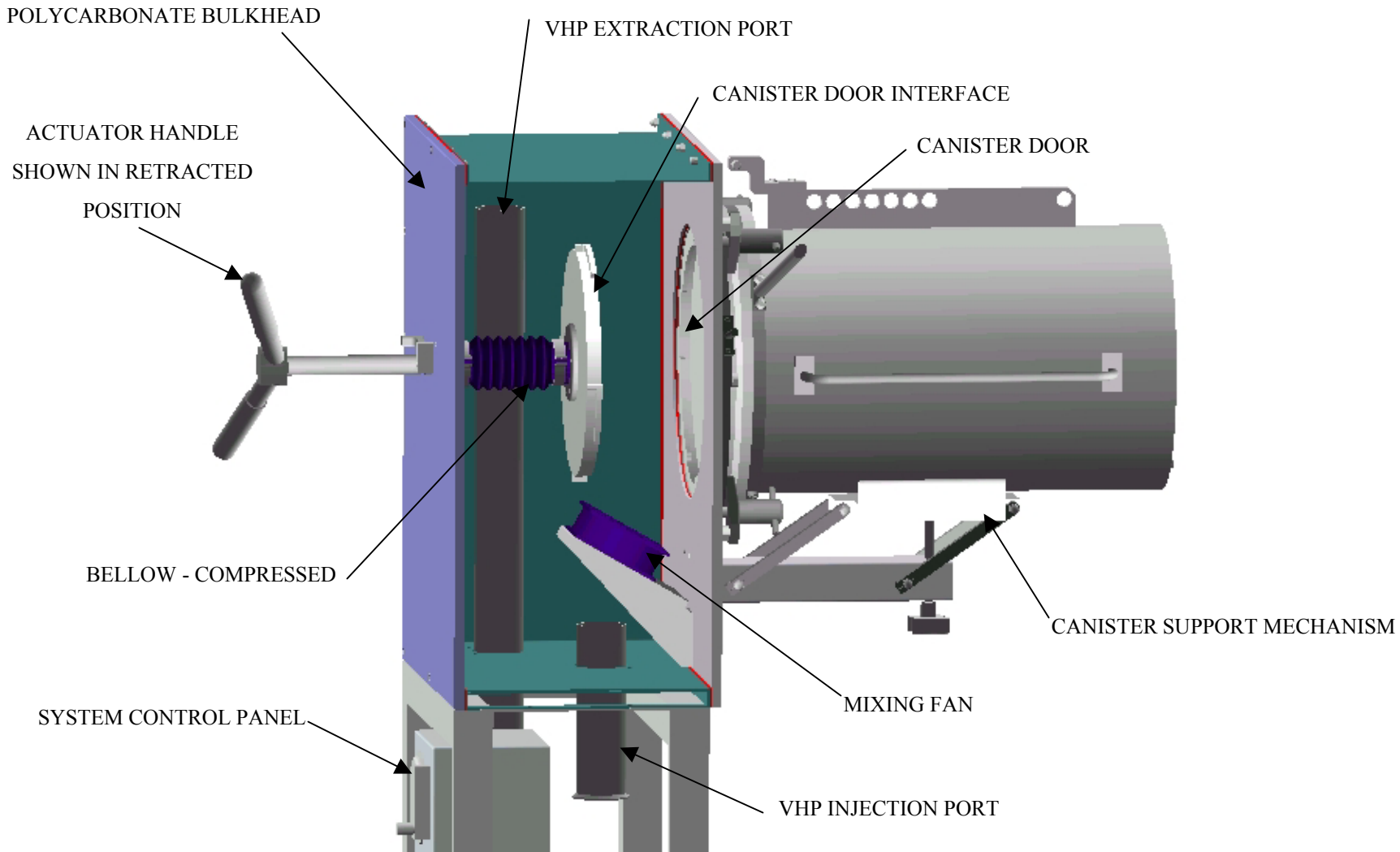

System shown upon docking of RTP canister

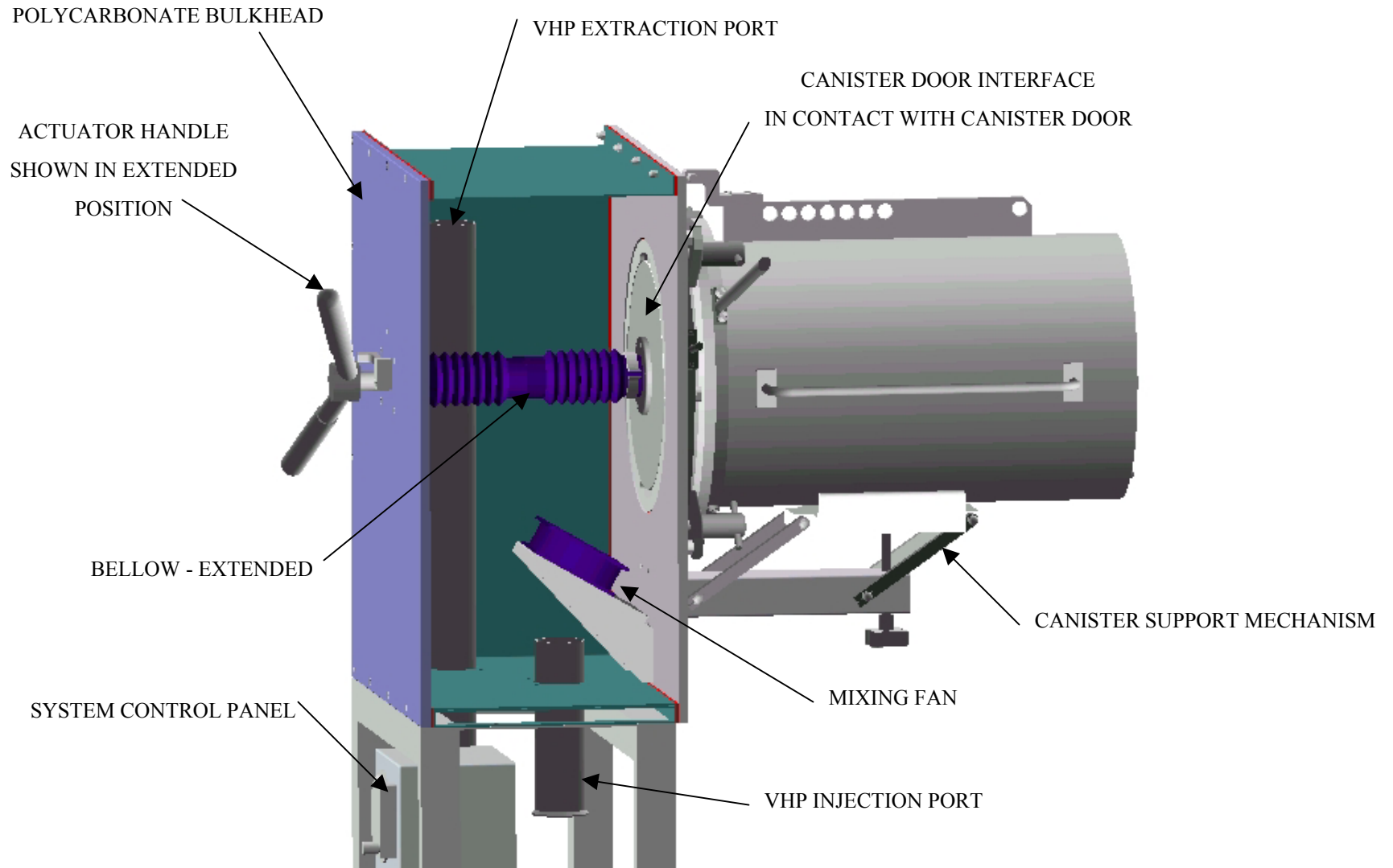

Canister door being removed

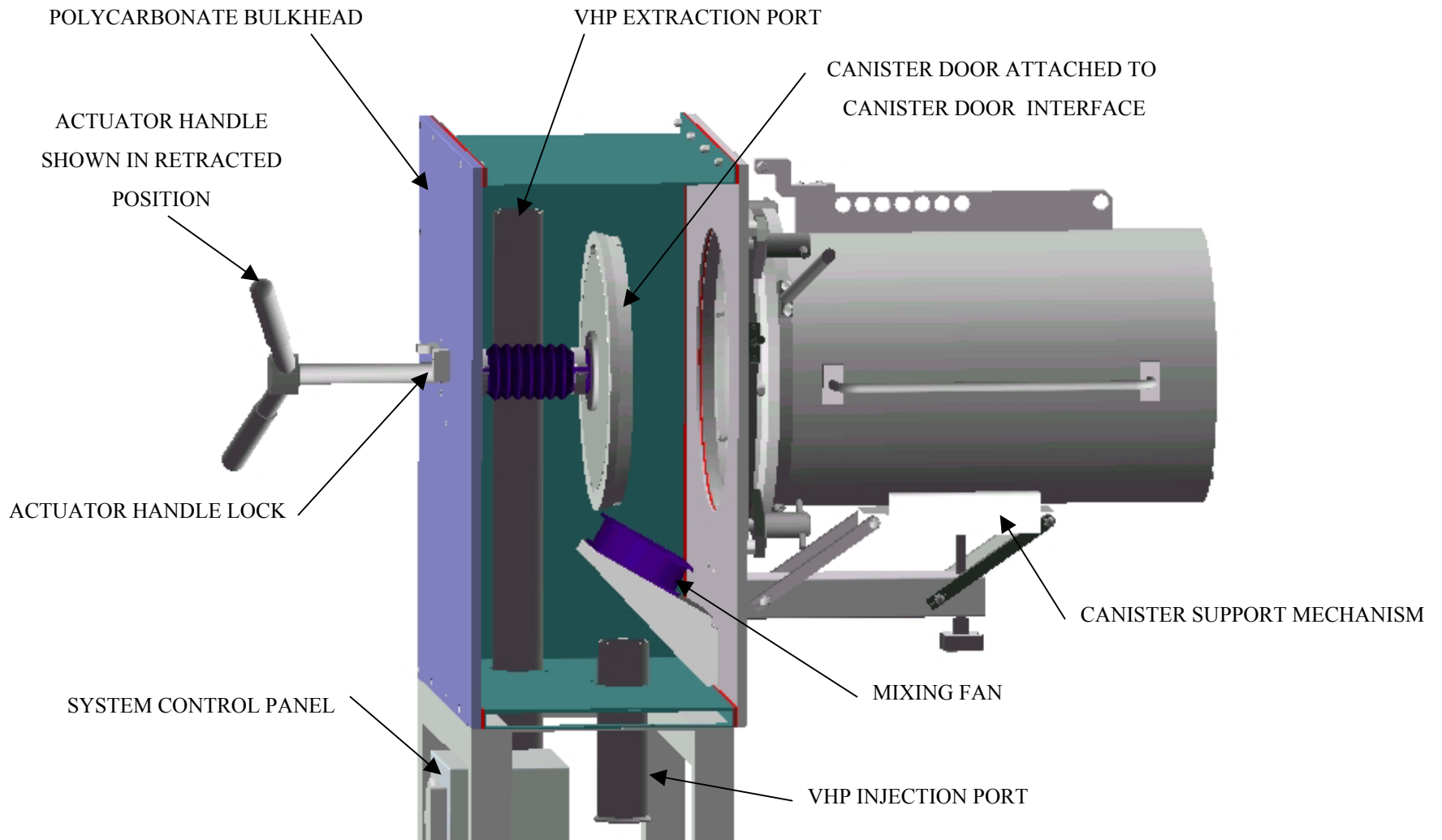

Canister door removed - Gassing

NON-ROTATING CANISTER
MAY BE ANY TYPE OF CANISTER

CANISTER INTERFACE
LOCKDOWN CLAMP

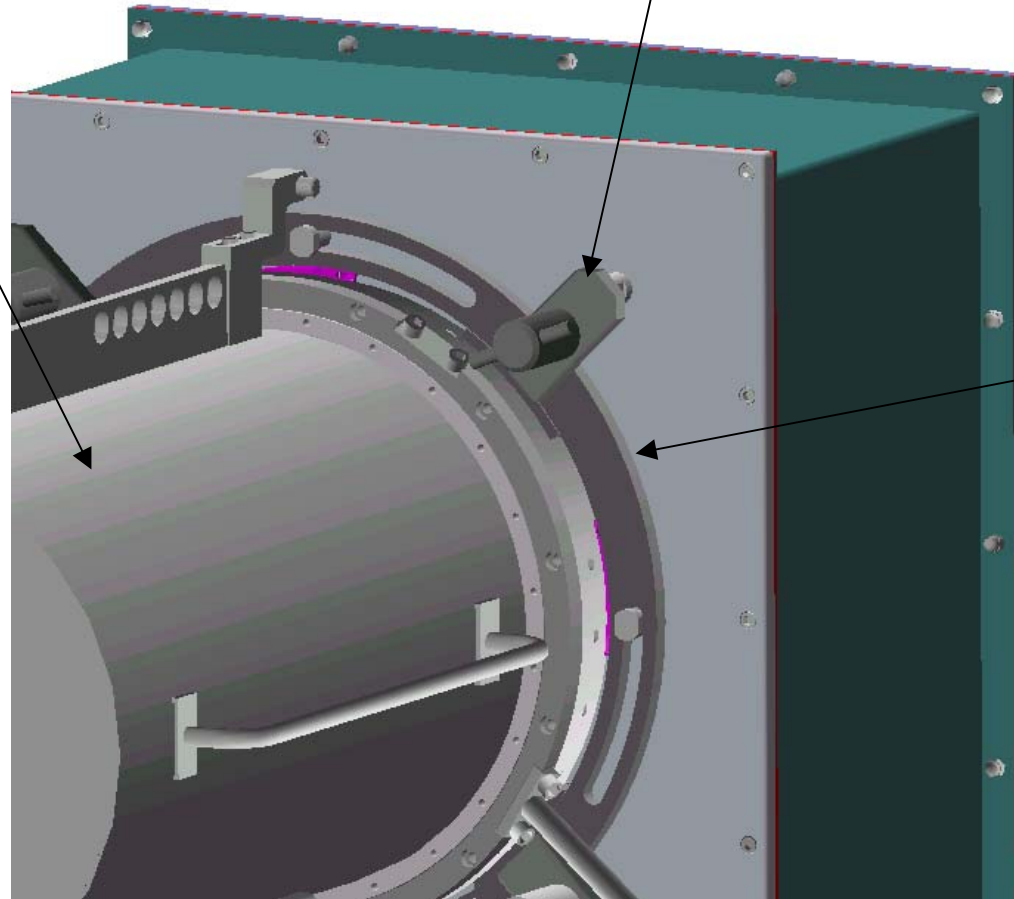

CANISTER INTERFACE
LOCK RING

Close up of locking mechanism